

Wieland

**Coaxial Heat Exchangers
WKE and WKC**

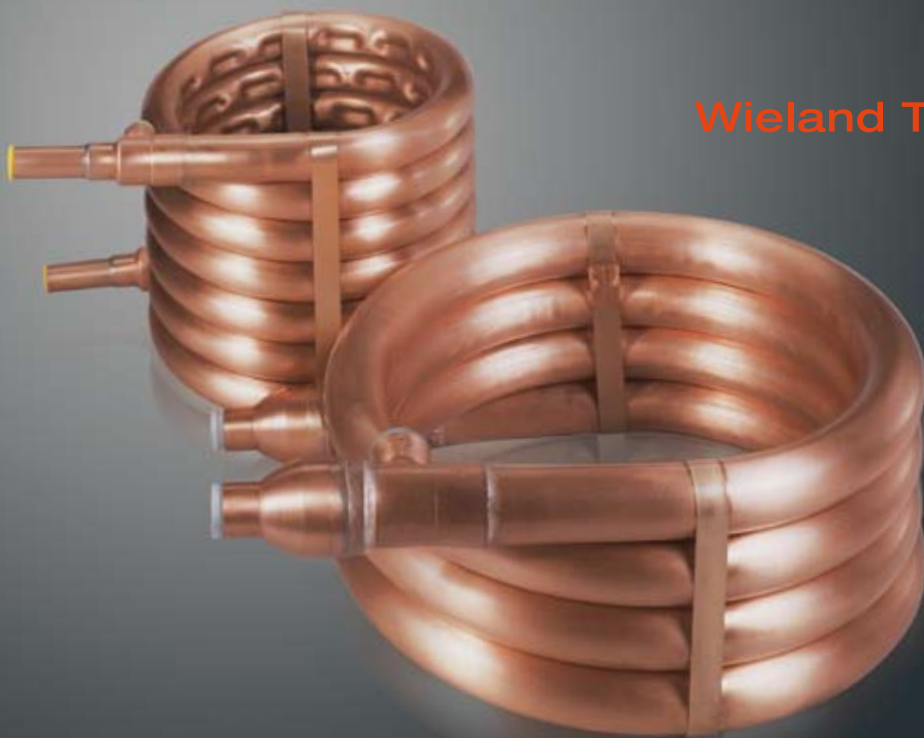

Wieland Thermal Solutions®
PROVIDING EFFICIENCY

Wieland WKE and WKC coaxial heat exchangers

Wieland coaxial heat exchangers are used as condensers (WKC) or as evaporators (WKE). Depending on their rating, they consist of one or more inner tubes and one outer tube. This tube bundle is coiled in a spiral shape and hard-soldered at the ends with T-fittings. Vibrationless mountings for the inner tubes are provided via beads in the jacket tube (WKC) or support rings (WKE). Wieland coaxial heat exchangers are made of copper or copper alloys.

WKE and WKC heat exchangers, developed at our in-house thermal engineering laboratory, have inner tubes specially optimised for condensation and evaporation. This results in a much higher specific performance and a very compact and comparatively lightweight design. Wieland coaxial heat exchangers are available as standard versions from stock or as tailor-made solutions.

Advantages

- High specific performance through optimised inner tubes
- Counter flow
- Frost-proof
- Low susceptibility to fouling
- Long life
- High system pressure possible (suitable for R410A)
- Adaptability of inner tube at operating pressure, e.g. for CO₂ applications
- Reversible operation possible
- Standard heat exchangers are available from stock (direct from us or via one of our trading partners)

Applications of Wieland coaxial heat exchangers (examples):

- Heat pumps for hot water
- Cold water condenser units
- Series heat exchangers in multistage refrigeration systems
- Devices for the simulation of environmental conditions
- Temperature control devices/climatic cabinets

WKC coaxial condensers

Coaxial condensers are normally used in applications which require high water temperatures in conjunction with the use of hot gaseous refrigerant. In counter-flow operation this is achieved with an optimised heat exchange. As a result, coaxial condensers offer excellent value for money.

WKE coaxial evaporators

Coaxial evaporators are the preferred choice in applications where water needs to be cooled a lot without freezing. At the same time they also offer reliable superheating of the suction vapour, which is facilitated by the counter-flow layout.

Materials

Innertubes, outertubes and T-fittings are made of oxygen-free copper (Cu-DHP to DIN EN 12452) and the soldered joints are made of hard solder to DIN EN 1044. For soldered seams there is the procedure qualification in accordance with AD Merkblatt (data sheet) HP 5/1.

Quality assurance

To ensure consistent product quality, Wieland-Werke AG has a sophisticated quality control system according to DIN EN ISO 9001 which has been verified and certified by the independent certification company, Bureau Veritas Quality International (BVQI). Since 30 December 2002, our test laboratories in the Central Laboratory and Development Services have been accredited to DIN EN ISO/IEC 17025 and DIN EN ISO 9001 as test and certification laboratories.

Technical service

Our Technical Marketing experts are available at any time as contact partners to work together with your experts from the very early product planning stages in order to obtain optimum results for the manufacturing stage and for your application. The only way to find the best, most cost-effective solution is by means of comprehensive technical consultation based on computerised thermal engineering rating.

Pressure Equipment Directive 97/23/EC

Wieland coaxial heat exchangers meet the requirements of the European Pressure Equipment Directive 97/23/EC. They are normally classified into the categories laid out in tables 2 and 3 and are manufactured and supplied in accordance with the measures designated for this purpose.

Operating conditions which exceed these specifications are subject to special requirements which should be agreed separately for each individual case.

Key:

Q_{cN} [kW]	Condenser performance under nominal conditions
Q_{oN} [kW]	Evaporator performance under nominal conditions
Δt_{cU} [K]	Undercooling of the refrigerant in the condenser
Δt_{oH} [K]	Overheating of the suction vapour
Δt_c [K]	$t_c - t_1$ temperature difference in the condenser
Δt_o [K]	$t_1 - t_o$ temperature difference in the evaporator
t_o [°C]	Evaporation temperature of the refrigerant at the evaporator outlet
t_c [°C]	Condensation temperature of the refrigerant in the condenser
t_H [°C]	Hot gaseous refrigerant temperature
t_1 [°C]	Water temperature at the inlet
V [m ³ /h]	Water volume flow
w [m/s]	Water velocity
x [-]	Vapour content at the evaporator inlet

Applications

	WKC (condenser)		WKE (evaporator)	
	Refrigerant (inside the coil)	Coolant (in the tubes)	Refrigerant (in the tubes)	Heating medium (inside the coil)
Maximum allowable working pressure [bar]	35	15	35	15
Maximum allowable working temperature [°C]	-50 to +150	-20 to +90	-50 to +150	-20 to +150
Media e. g.	R134a, R404A, R407C, R410A, R22, R507 (other refrigerants on request)	Drinking water or hot water, circulating water, (e. g. heating water), groundwater*, swimming pool water** (other cooling media on request)	R134a, R404A, R407C, R410A, R22, R507 (other refrigerants on request)	Circulating water (e. g. heating water), groundwater*, water with anti-freeze additives (e. g. Antifrogen N®) (other heating media on request)

Table 1 **Individual case assessment recommended; **Up to approx. 5 mg/l free chlorine

Performance rating overview

The following diagrams can be used to pre-select your Wieland coaxial heat exchanger according to the performance of the condenser/evaporator. The specified values are based on our own measurements. They should be used as reference values only and apply under the described nominal conditions which conform as far as possible to the corresponding standards (e.g. EN 1117: Liquid cooled refrigerant condensers - test procedures for establishing the performance).

Operating conditions which vary from these conditions may result in different values. Detailed measurement and design data for different refrigerants and application media are available in the form of design software.

Design software

Wieland-Werke AG has design software for the selection and dimensioning of the coaxial heat exchangers. The software is available free of charge on CD-ROM or for free download from our Wieland Thermal Solutions (www.wieland-thermalsolutions.com) website.

WKC condenser

Refrigerant: R134a; $t_c = 45\text{ °C}$; $t_H = \text{ca. } 65\text{ °C}$; $\Delta t_{cU} = 4\text{ K}$
Coolant: water; $w \approx 0.5\text{ to } 2\text{ m/s}$

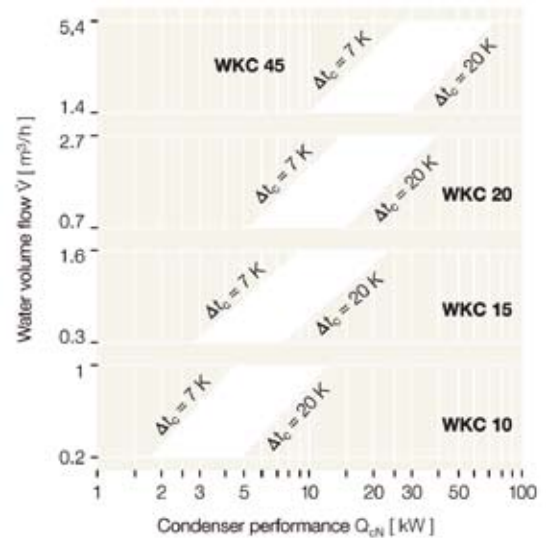

WKE evaporator

Refrigerant: R134a; $t_0 = 0\text{ °C}$; $x = 20\text{ \%}$; $\Delta t_{0H} = \text{ca. } 5\text{ K}$
Heating medium: water; $w \approx 0.5\text{ to } 2\text{ m/s}$

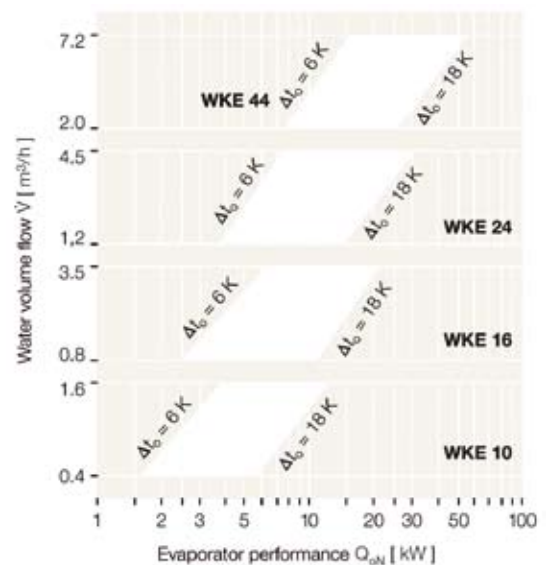

Installation information

Coaxial heat exchangers should preferably be operated in counter flow operation.

The WKC condensers are installed so that the liquefied refrigerant is free to drain away to the bottom. The hot gaseous refrigerant gas enters the encasing space at the top, whereas the cooling medium (e.g. water) enters the inner tube(s). Coaxial condensers are also installed standing on the windings (winding axis horizontal). If an application requires several condensers to be connected in parallel, then the tubework should be routed in such a way that each condenser can be supplied with even pressure on both the refrigerant side and the cooling medium side.

The routing of the hot gas line should be installed avoiding any vibrations. This is normally achieved by installing vibration

dampers (compensation). In order to avoid pulsating noises, we recommend installing a sound muffler between the compressor and the condenser. Please follow the manufacturer's instructions when installing these components.

The installation of WKE evaporators preferably allows the refrigerant to enter through the upper connection. If several evaporators of the same size are to be connected in parallel, then it must be ensured that each evaporator is supplied with even pressure both on the refrigerant side and on the heating medium side. With Wieland coaxial heat exchangers, the following proportions of the refrigerant side volume (taken from tables 2 and 3) should be used as an approximation for the calculation of the refrigerant capacity of the overall system:

- for the WKC coaxial condenser: 30 %
- for the WKE coaxial evaporator: 40 %

Dimensions and weights of the WKC coaxial condensers

Model	Number of inner tubes	Maximum installation dimensions			Connection dimensions (see drawing)			Other dimensions						Volume [l]		Classification PED 97/23/EC	Appr. weight [kg]
														Coolant	Refrigerant		
A	B	H	d ₂ * and d ₃ *	d ₄ **	d ₁ *	a	h	l ₁ and l ₃	l ₂ and l ₄	l ₅	D	Coolant	Refrigerant				
WKC 10	1	225	270	135	12.7	15.9	16	190±5	98±5	262	55	26	25	0.3	0.55	sound engineering practice	3.5
WKC 15	1	230	290	235	16	19	18	190±5	196±5	282	71	28	28	0.8	1.0	sound engineering practice	7.5
WKC 20	1	350	360	220	21.7	25.5	22	300±5	172±5	350	77	36	35.6	1.75	1.8	Category 1, Module A	10.5
WKC 45	4	520	530	225	28	31.9	35	445±5	152±5	522	142	76	54	2.9	3.65	Category 1, Module A	21.0

Table 2 – all dimensions in mm (unless specified otherwise); *Internal soldering ends; **External soldering ends

Dimensions and weights of WKE coaxial evaporators

Model	Number of inner tubes	Maximum installation dimensions			Connection dimensions (see drawing)			Other dimensions						Volume [l]		Classification PED 97/23/EC	Appr. weight [kg]		
														Heat. medium	Refrigerant				
A	B	H	d ₁ *	in d ₂ *	out d ₃ *	a	h	l ₁	l ₂	l ₃	l ₄	l ₅	D						
WKE 10***	1	330	325	130	16	13	13	290±5	94±5	312	65	312	65	24	25	0.8	0.4	sound engineering practice	4.1
WKE 16	2	340	390	190	28	22	22	290±5	140±5	384	91	384	91	41	35.6	1.8	0.9	sound engineering practice	8.1
WKE 24	3	435	465	175	28	18	18	380±5	122±5	457	125	457	125	102	43	2.4	1.3	sound engineering practice	11.1
WKE 44	5	605	600	220	35	22	28	530±5	150±5	564	123	549	123	54	54	4.9	2.9	Category 1, Module A	24.7

Table 3 – all dimensions in mm (unless specified otherwise); *Internal soldering ends; **External soldering ends; ***For WKE 10 the fitting on the cooling-medium side can also be used as external soldering end d₄ with Ø 16 mm (e.g. for tube Ø 18 x 1.0 mm).

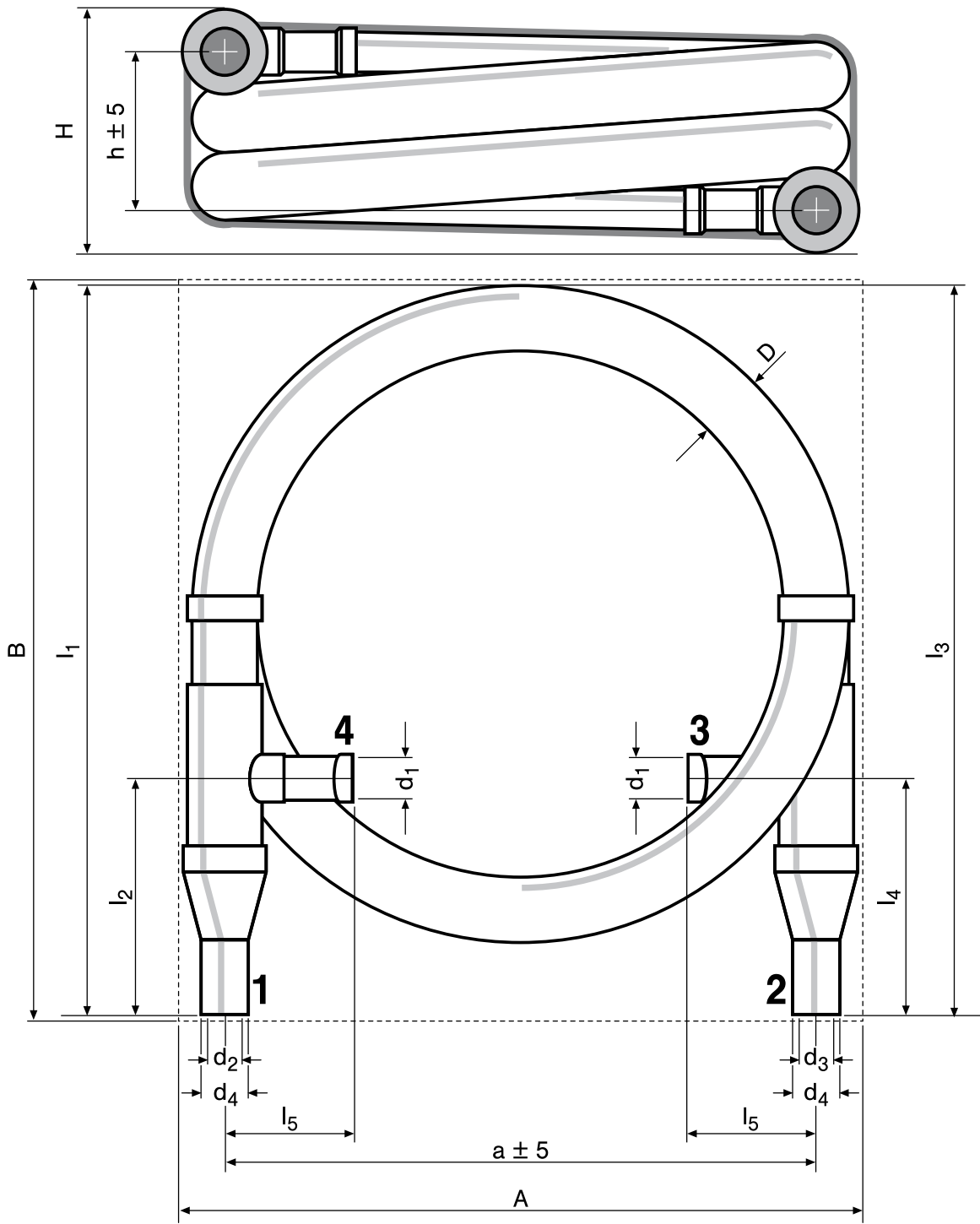

WKC condensers

- 1 Coolant outlet
- 2 Coolant inlet
- 3 Refrigerant outlet
- 4 Refrigerant inlet

WKE evaporators

- 1 Refrigerant inlet
- 2 Refrigerant outlet
- 3 Heating medium inlet
- 4 Heating medium outlet



Wieland-Werke AG

www.wieland-thermalsolutions.com

Graf-Arco-Str. 36, 89079 Ulm, Germany, Phone +49 (0)731 944-0, Fax +49 (0)731 944-2213, info@wieland.de

This brochure is for your general information only and is not subject to revision. No claims can be derived from it unless there is evidence of intent or gross negligence. The data given are no warranty that the product is of a specified quality and they cannot replace expert advice or the customer's own tests.